

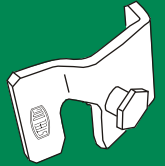

# Angle Corner Clips

1-1/8" Forming Hardware

1-1/8" SYSTEM



CC-22 22.5°



CC-30 30°



CC-45 45°



CC-45's Used on Bay Window Corners

Steel Dog™ Angle Corner Clips are a fast, inexpensive alternative to full-height, metal outside corners. Available in 22.5°, 30°, and 45° versions, these clips slip tightly onto the end of the panel bar, converting a pair of standard filler panels into a corner in seconds. Reduce the number of heavy, expensive, and maintenance-prone full-height corners in your inventory.

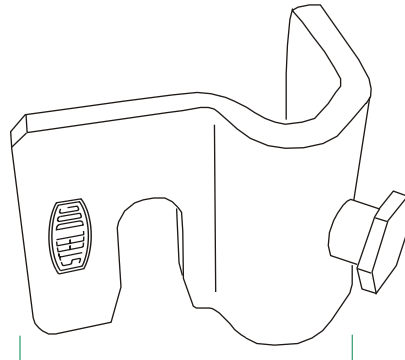

Full-height metal inside corner, fixed or hinged

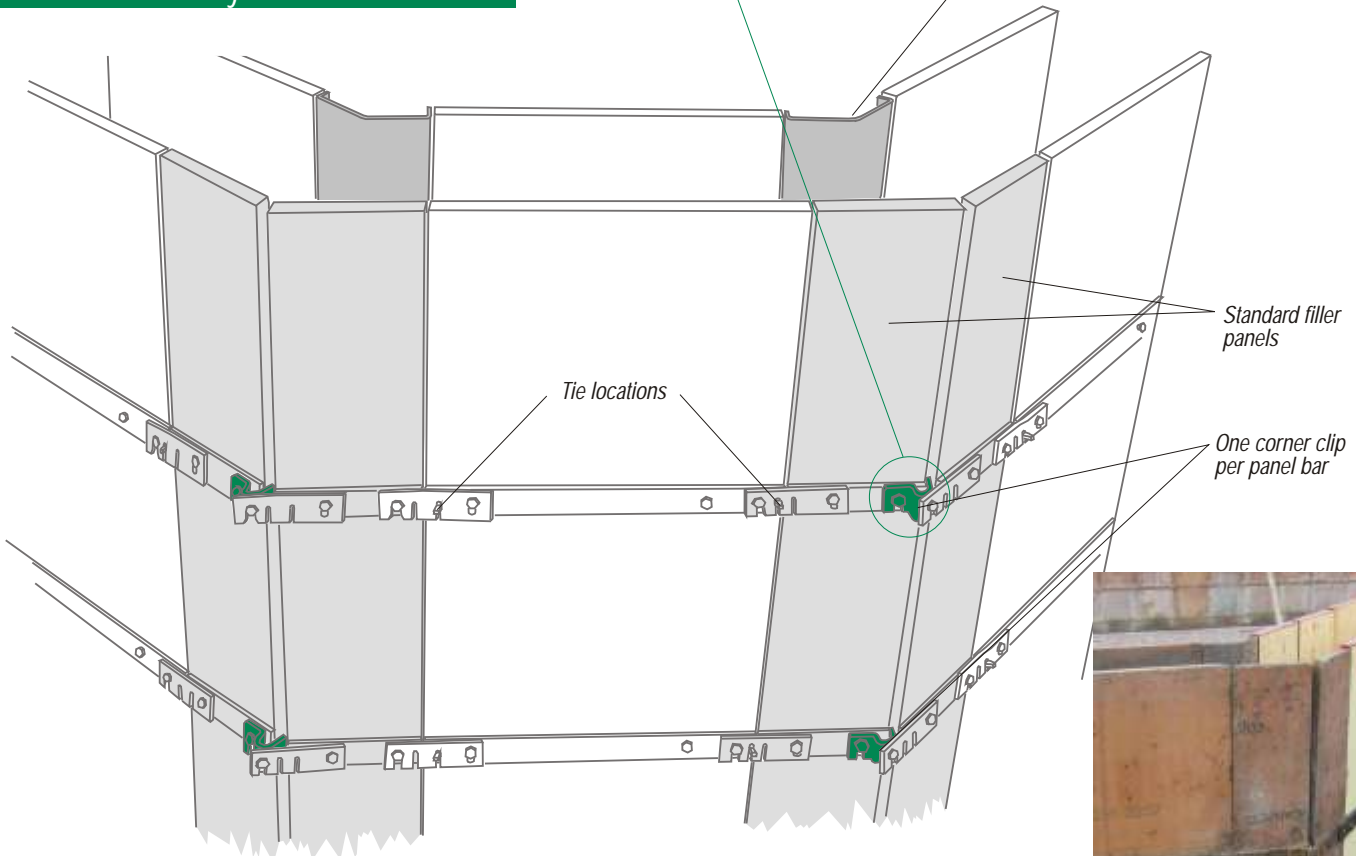

## Put your filler panels to work as outside corners.

Instead of putting your money into dedicated full-height metal corners that will sit idle much of the time, spend up to 65% less on a set of corner clips and get double-duty out of your existing filler panels. Have a mixed inventory of panels? Angle Corner Clips can be used on panels of any height, with any number of bars. CC-45 clips can even be used for outside 90° corners (see other side).



## Calculating Filler Panel Width

The filler width depends on wall thickness and corner angle.

To get the ties nearest to the corner to line up, and for uniform wall thickness, the proper width fillers need to be selected. The exact width to match 4" x 4" inside corners in most cases is not a standard filler, but the nearest whole inch size is usually a good approximation. Use the table below to determine the right filler width for your application.

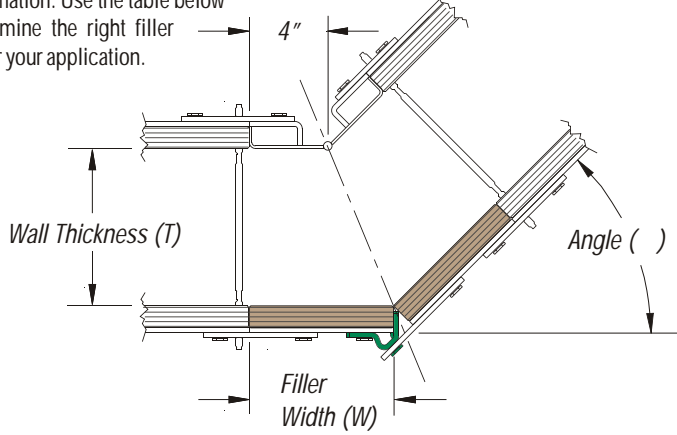

### Filler Panel Width (W) for Given Wall Thickness and Corner Angle

Corner Clip Angle (°)	Wall Thickness (T) in Inches					
	6	8	10	12	14	16
22.5°	5¼	5⅝	6	6⅜	6¾	7⅛
30°	5⅝	6⅞	6⅝	7¼	7¾	8¼
45°	6½	7⅞	8⅞	9	9¾	10⅝

The values in the table are rounded to the nearest 1/8" and are based on using a 4" x 4" hinged or fixed-angle inside corner. Use the closest size filler panel to the value listed. For instance, for a 30° corner on an 8" wall, 6" filler panels would be a good choice.

## Piggybacking Clips for Additional Angles

Extra angles for free.

Need an oddball angle? Or how about a few extra 90° outside corners for a big job? All Steel Dog™ Angle Corner Clips will "piggyback" onto each other, giving you additional capability with the same set of clips.

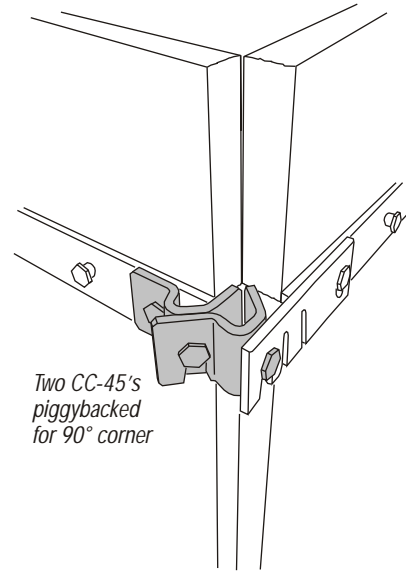

### Some Combinations:

- 22.5° + 22.5° = 45°
- 22.5° + 30° = 52.5°
- 30° + 30° = 60°
- 22.5° + 45° = 67.5°
- 30° + 45° = 75°
- 45° + 45° = 90°

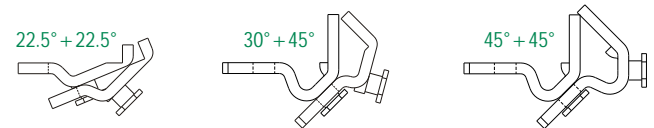

Tired of bent 1 x 1 outside corners? Steel Dog 90 Degree Corner Clips are an indestructible, economical alternative. Ask your dealer.

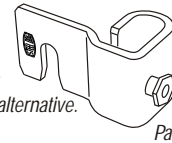

Patent Pending



## Curved Wall Forming with CC-22 Clips

A fast way to form curved walls.

The CC-22 can help with certain curved-wall forming jobs. The shoulder bolt on the CC-22 acts as a pivot for the swing latch, allowing the adjacent panel to be placed at an angle between 12 and 22 degrees. Although this opens up a narrow gap in between panels, a thin plywood form liner (shown below) can be used in critical locations.

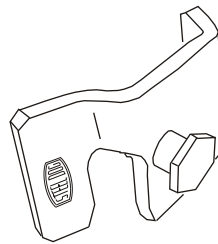

On the inside, just use the swing latches to connect the panels and catch the ties.



### Select your filler panels.

Adjust widths of inside vs. outside panels to form desired radius. The ability to form a particular radius with the CC-22 clips depends on two factors: 1) the width of filler panels used, and 2) the condition of the panels and latches.

It is best to experiment with your forms to see what combinations of fillers will give you the radius you want and still allow you to swing the latches and catch the ties. (The curved wall shown here is approximately 6 ½ ft outside radius).

